



**BROWN & GAMMONS LTD**

Tel: 01462 490049 Fax: 01462 491940

[www.ukmgparts.com](http://www.ukmgparts.com)

[sales@ukmgparts.com](mailto:sales@ukmgparts.com)

## FITTING INSTRUCTIONS MGR V8 FRONT HUB BEARING KIT (GHK1594)

### PLEASE NOTE:

Two designs of front hub bearing assembly have been used on the MGR V8 during production. The specifications changed at axle cross member assembly, part number PE2316. This number is stamped on the near side rear fixing leg of the front suspension cross member and can be viewed by looking behind the rear of the near side front road wheel.

The hub bearing assembly supplied in this kit can be used to replace both designs providing the following actions are taken:

Vehicles after cross member part number PE2316 have a hub assembly and stub axle which is identified by two machined grooves - one on the end of the stub axle and the other around the outer edge of the wheel flange on the hub itself (see figure 1).

The hub supplied in this kit is a direct replacement for the one originally fitted.

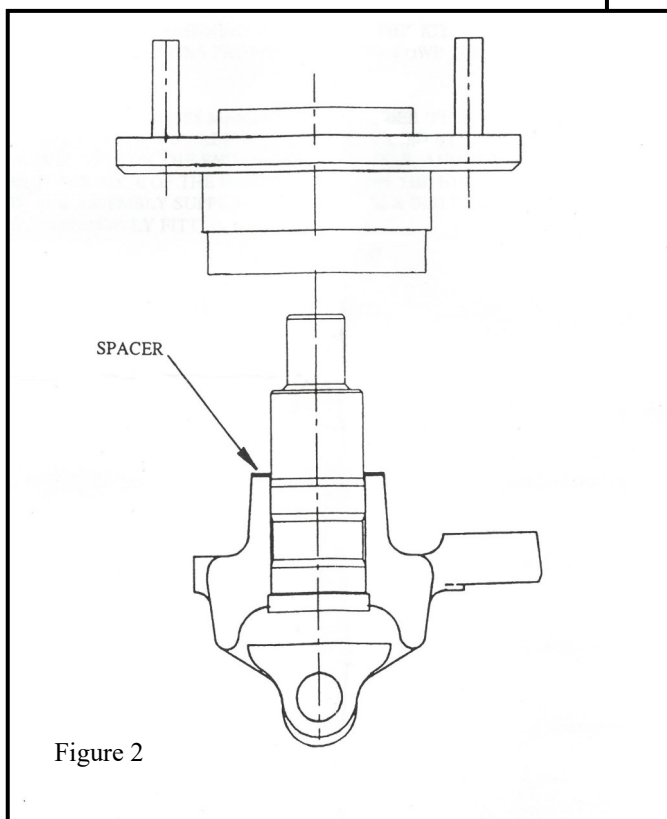
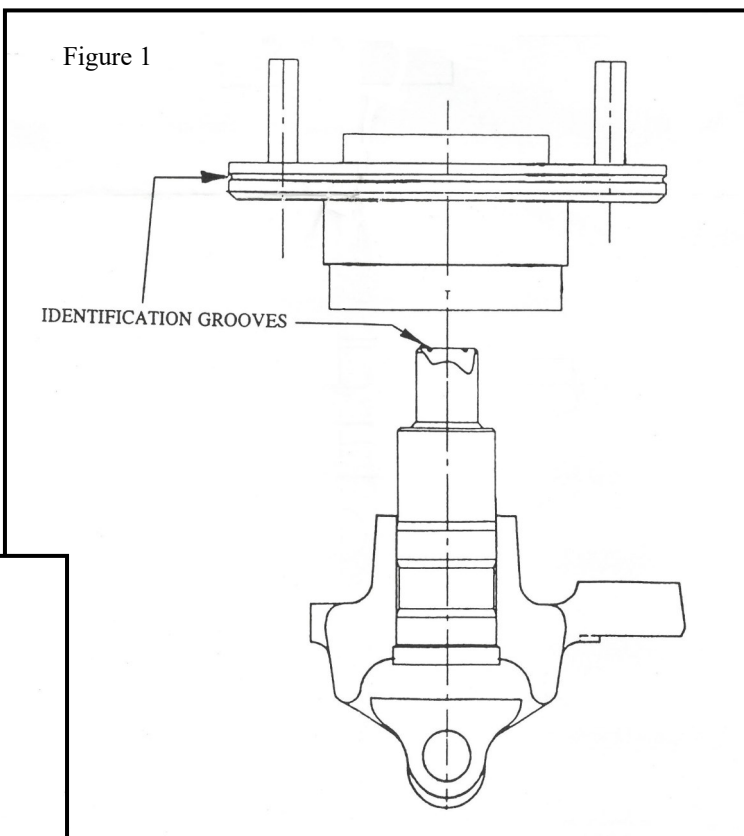

The hub and stub axle on vehicles prior to axle cross member number PE2316 have no identification grooves. When replacing this design with the hub assembly supplied in this kit, the spacer provided must also be used.

This must be pushed onto the stub axle and located against the bearing inner race abutment face (see figure 2).

Figure 2



**BROWN & GAMMONS LTD**

Tel: 01462 490049 Fax: 01462 491940

[www.ukmgparts.com](http://www.ukmgparts.com)

[sales@ukmgparts.com](mailto:sales@ukmgparts.com)

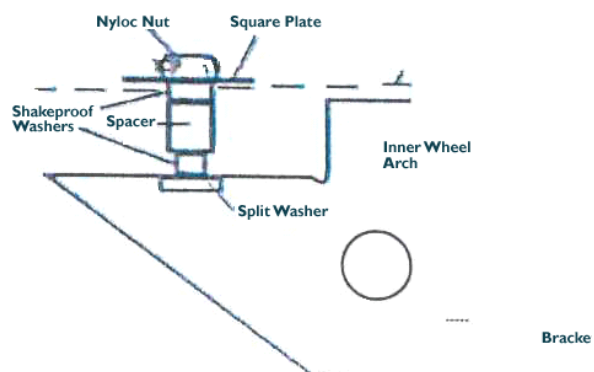
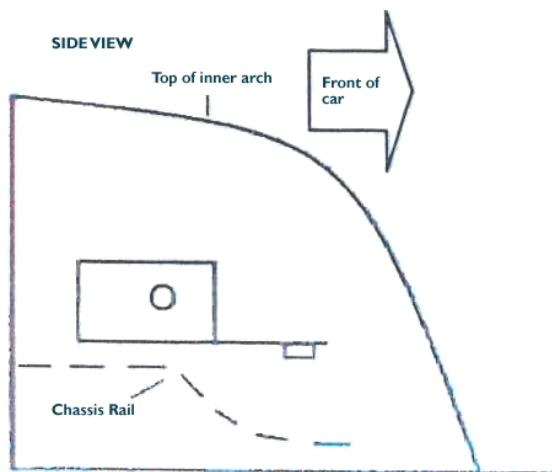

LEFT HAND SEAT BELT

RIGHT HAND SEAT BELT





**BROWN & GAMMONS LTD**

**Tel: 01462 490049 Fax: 01462 491940**

**[www.ukmgparts.com](http://www.ukmgparts.com)**

**[sales@ukmgparts.com](mailto:sales@ukmgparts.com)**

